

Specification for:

0W40905UG

110 Delta Drive
Pittsburgh, PA 15238
Phone: 412/696-1333
Fax: 412/696-0333
Email:magnetics@spang.com

DIMENSIONS

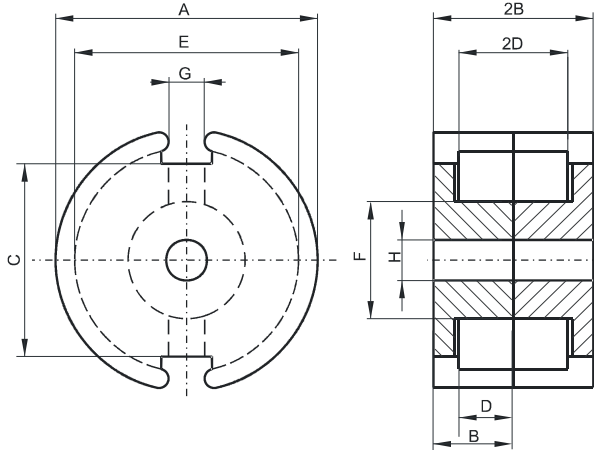

(mm)	Nominal:	Tol. min.:	Tol. max.:
A	9.3	-0.3	0.0
B	2.7	-0.15	0.0
2B	5.4	-0.3	0.0
C	6.5	-0.25	+ 0.25
D	1.8	0.0	+ 0.15
2D	3.6	0.0	+ 0.3
E	7.5	0.0	+ 0.25
F	3.9	-0.2	0.0
G	2.0	-0.2	+ 0.2
H	2.04	0.0	+ 0.06
Eff. Parameters			
Ae mm²	Amin mm²	le mm	Ve mm³
10.1	8.0	12.5	126

INDUCTANCE

AL value (nH)	Test conditions
Nom: 6029 Min.: 4220	10 kHz, < 0.5 mT, 25 °C

MARKING

No marking

LOSS FACTOR

$\tan \delta/\mu$ ($\times 10^{-6}$)	Test conditions
< 3	10 kHz, < 0.25 mT, 25 °C
< 45	100 kHz, < 0.25 mT, 25 °C

NOTE

Spec. modifications	Previous	Revised
2005-06-22	B=2.57 Min. 2B=5.14 Min. C=5.14 Min. F=3.88 Max. G=1.93 Nom. G=1.78 Min. H=2.01±0.05 Loss factor: General W material Marking	B=2.55 Min. 2B=5.1 Min. C=6.5 Nom. F=3.9 Max. G=2.0±0.2 H=2.04 Min. H=2.1 Max. Loss factor: Detail as indicated No marking