

**DIMENSIONS**

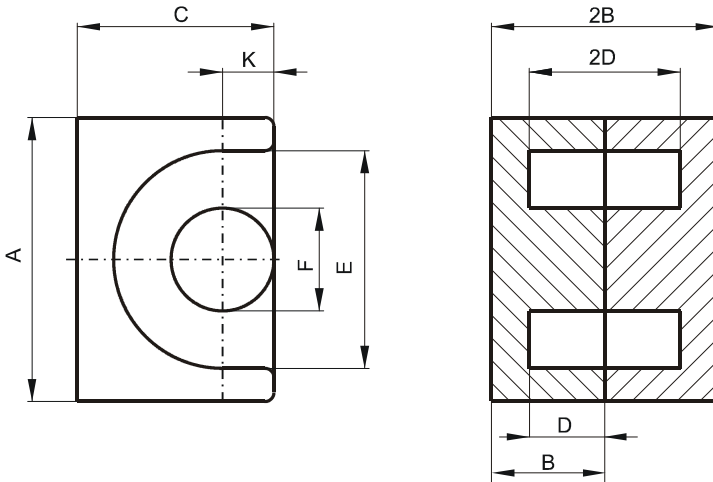

(mm)	Nominal:	Tol. min.:	Tol. max.:
<b>A</b>	11.5	-0.3	+ 0.3
<b>B</b>	5.15	-0.1	+ 0.1
<b>2B</b>	10.3	-0.2	+ 0.2
<b>C</b>	7.6	-0.2	+ 0.2
<b>D</b>	3.6 Min.		
<b>2D</b>	7.2 Min.		
<b>E</b>	9.2 Min.		
<b>F</b>	3.45 Max.		
<b>K</b>	1.85	-0.1	+ 0.1
<b>Eff. Parameters</b>			
<b>Ae mm<sup>2</sup></b>	<b>Amin mm<sup>2</sup></b>	<b>le mm</b>	<b>Ve mm<sup>3</sup></b>
11.3	8.55	19.3	215

**INDUCTANCE**

AL value (nH/T <sup>2</sup> )	Test conditions
1200 ± 25%	10 kHz, < 0.5 mT, 25 °C

**MARKING**

No marking

**CORE LOSSES**

P <sub>i</sub> max	Test conditions
< 0.118 W/set (< 550 mW/cm <sup>3</sup> )	100 kHz, 200 mT, 25 °C
< 0.12 W/set (< 520 mW/cm <sup>3</sup> )	100 kHz, 200 mT, 100 °C

**NOTE**

Spec. modifications	Previous	Revised
2005-06-22	2B=10.46 Max. B=5.23 Max. C=7.44 Min.	2B=10.5 Max. B=5.25 Max. C=7.4 Min.